

# BOMAC

エクストラ ワークス エクストラ ストロング

# FORKLIFT

# ELECTRIC



## RE40-50

## EXTRA WORK, EXTRA STRONG

After more than 30 years of development, BOMAC has grown into a large company and a world-class forklift exporter and has been widely used in The World.



- The voltage is increased from 80V of traditional lithium battery powered truck to 153.6V. The overall energy efficiency is significantly improved by increasing of the motor power and reducing of the current of motor and controller.
- Permanent magnet synchronous motor for electric vehicle which has lighter mass compared with the same energy three-phase asynchronous motor is adopted and the comprehensive efficiency is significantly improved.
- Standard load sensing is equipped on the truck as standard which gives priority to steering and saves energy by 5%;

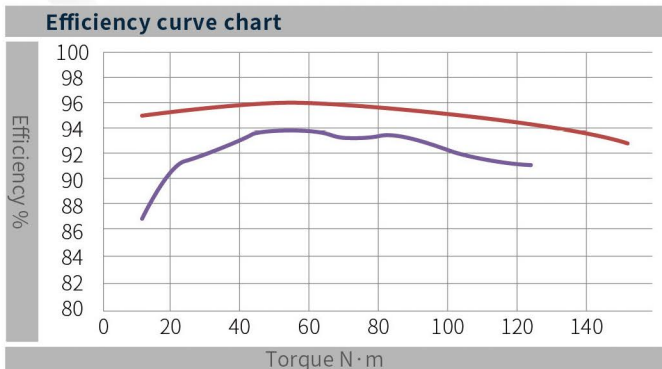

- Driving efficiency of three-phase asynchronous motor on flat ground.
- Driving efficiency of permanent magnet synchronous motor on flat ground.



The integrated power system reduces the wiring harness which greatly reduces the loss of electric energy transmission. And the levels of parts and control modules are clear and convenient for maintenance;

<b>Driving speed</b> 18km/h	<b>Gradient with load</b> 17%	<b>Lifting Speed with load</b> 380mm/s	<b>Lifting Speed without load</b> 500mm/s	<b>The acceleration time of 10m at full load is reduced by 20%</b>

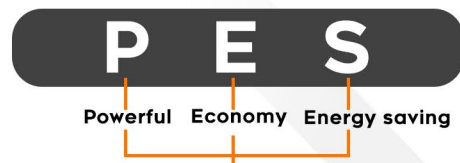

Multi gear performance modes meet your requirements for different working condition.

**Smart safety functions offer comprehensive guarantee.**



Emergency power-off switch is equipped as standard to ensure safety in case of emergency;



High efficiency liquid cooling and heat dissipation system is equipped as standard, which can meet the requirements of automobile S1 continuous working system;



System level voltage safety protection: The truck features Integrated / shortest design of voltage connection and multiple insulation monitoring protection;

System level voltage safety sectional design: when the maintenance switch is pulled out, the system fails or the key is disconnected, the voltage system will be automatically disconnected, and the maximum voltage shall not be greater than 76.8V

- **Steering deceleration function:** the standard steering automatic deceleration function can reduce the risk of tipping when steering;

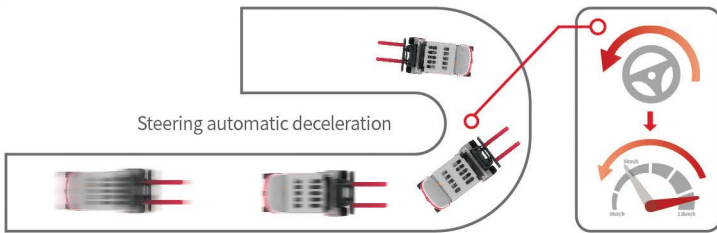

**Color screen instrument:** it has the functions of full display of truck information, timely reminder and convenient operation;



## Internal combustion platform, stable and reliable

- The whole truck is developed based on the internal combustion truck platform, and all parts are mature and reliable. It has the advantages of high performance, high stability and high environmental adaptability of the internal combustion truck, as well as the green and environmental protection characteristics of the lithium truck.



## Ergonomic Design, Intelligent and Comfortable



Buffering under the mast makes goods handling operation more comfortable;



When the tilt cylinder sinks down in layout, the upper space of the bottom plate increases and the leg space is enlarged;



The armrest is equipped with horn switch for reversing, which makes driving safer;



The whole truck is equipped with USB interface and folder as standard;



Ratchet type parking brake operating handle offers more labor-saving operation;



Wide view mast optimize the blind area of operation vision and it is comfortable and safe for operation;

## Centralized maintenance points, Fast and convenient for maintenance

- The truck features 80° hood opening angle and simple opening mechanism. The key lock is optional.
- Optimized layout of truck structure offers large internal space and convenient maintenance;
- Modular design of power assembly and electrical system offer convenient maintenance and low cost;

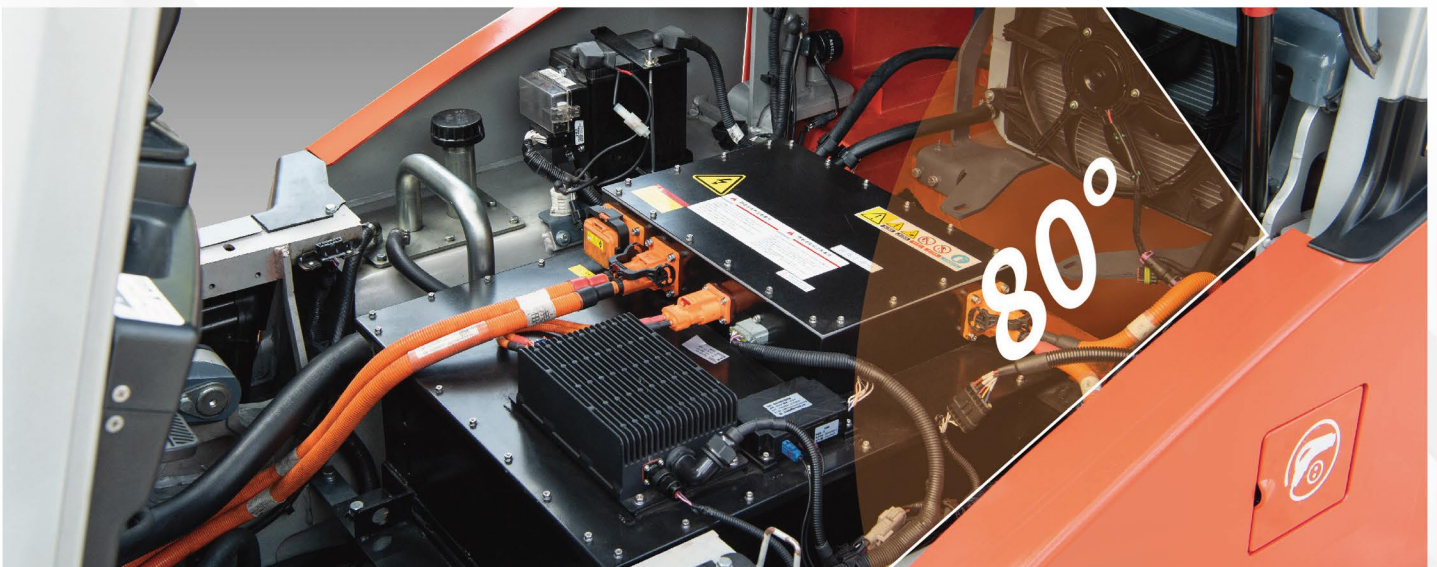

## MANUFACTURER AND TECHNICAL DATA

### Characteristic

1.01	Manufacturer					
1.02	Model			RE40	RE45	RE50
1.03	Configuration number			G2AL1L1		
1.04	Rated capacity	Q	Kg	4000	4500	5000
1.05	Load center distance	C	mm	500		
1.06	Power mode			Lithium battery		
1.07	Driving mode			Sit-on type		
1.08	Front overhang	x	Mm	560		
1.09	Wheelbase	y	mm	2100		

### Weight

2.01	Total weight		Kg	5890 / 5590	6245 / 5945	6600 / 6300
2.02	Axle load (laden, front/rear)		Kg	8990 / 900	9720 / 1025	10430 / 1170
2.03	Axle load (unladen, front/rear)		Kg	2970 / 2920	2950 / 3295	2900 / 3700

### Tyres

3.01	Tyre type			Solid Tyre		
3.02	Tyre size, front			8.25-15	300-15	
3.03	Tyre size, rear			7.00-12		
3.04	Wheels, number front/rear (x=driven wheels)			2X/2 (Dual tyre 4X/2)		
3.05	Tread, front	b <sub>10</sub>	mm	1180		
3.06	Tread, rear	b <sub>11</sub>	mm	1190		

### Dimensions

4.01	Mast tilt angle (forward/backward)	A/β	°	6/12		
4.02	Height (mast lowered)	h <sub>1</sub>	mm	2275		
4.03	Free lifting height	h <sub>2</sub>	mm	150		
4.04	Lifting height (standard)	h <sub>3</sub>	mm	3000		
4.05	Max. height, extended (with backrest)	h <sub>4</sub>	mm	4250		
4.06	Height of overhead guard	h <sub>6</sub>	mm	2350		
4.07	Seat height relating to SIP (to ground)	h <sub>7</sub>	mm	1080		
4.08	Towing coupling height	h <sub>10</sub>	mm	430		
4.09	Overall length (with fork)	l <sub>1</sub>	mm	4255	4275	4325
4.10	Overall length (without fork)	l <sub>1</sub>	mm	3185	3205	3255
4.11	Overall width	b <sub>1</sub>	mm	1480		
4.12	Fork size thickness x width x length	s/e/l	mm	50x150x1070		
4.13	Fork carriage, according to IS02328			III		
4.14	Distance across fork-arms, Max./Min.	b <sub>5</sub>	mm	1340/300		
4.15	Ground clearance (laden, between mast)	m <sub>1</sub>	mm	150		
4.16	Ground clearance (center of wheelbase)	m <sub>2</sub>	mm	230		
4.17	Right angle stacking aisle width for pallet 1000 x1200mm crossways	Ast	mm	4610	4640	4690
4.18	Right angle stacking aisle width for pallet 800 x1200mm lengthways	Ast	mm	4810	4840	4890
4.19	Min. outside turning radius	Wa	mm	2850	2880	2930

### Performance Data

5.01	Travel speed (laden / unladen)		km/h	18/19	18/19	18/19
5.02	Lift speed (laden / unladen)		m/s	450/500	420/500	390/500
5.03	Lowering speed (laden / unladen)		m/s	470/500	470/500	470/500
5.04	Max. drawbar pull (laden/unladen)		N	23000/20000	23000/20000	23000/20000
5.05	Max. gradeability (laden/unladen)		10%	19/20	18/20	17/20
5.06	Acceleration time (10m) (laden / unladen)		s			

### Battery

6.01	Voltage / capacity (K5)		V/Ah	153.6/230 (Optional 153.6/330)		
6.02	Mass (Min./Max.)		Kg	330/435		

### Motor and controller

7.01	Power of driving motor (S2-60min)		Kw	25		
7.02	Power of lifting motor (S3-15%)		Kw	20		
7.03	Control mode of driving motor			MOS tube / AC		
7.04	Control mode of lifting motor			MOS tube / AC		

### Addition data

8.01	Service brake / Parking brake			Hydraulic power assisted braking / mechanical- ratchet type		
8.02	Operating pressure for attachments.		Mpa	14		

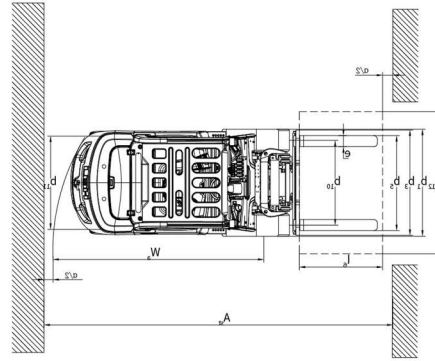
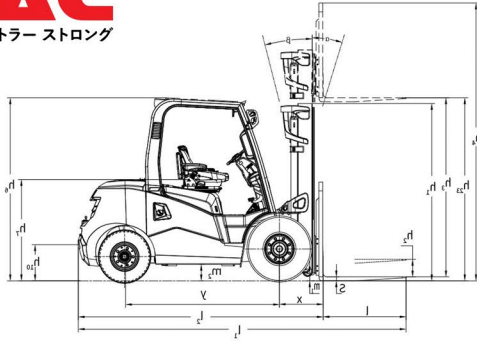

### WIDE VIEW STANDARD MAST

Mast Model	Max. Lifting Height (mm)	Load Capacity (Load Center 500mm) (Kg)			Height (mast lowered) (mm)	Free lift (with backrest) (mm)	Service Weight (Kg)			Mast Tilt angle $\alpha/\beta$ (°)
		4t	4.5t	5t			4t	4.5	5t	
M250	2500	4000	4500	5000	2000	150	5880	6140	6550	6°/12°
M300	3000	4000	4500	5000	2250	150	5930	6190	6600	6°/12°
M330	3300	4000	4500	5000	2400	150	5960	6220	6630	6°/12°
M350	3500	4000	4500	5000	2500	150	5980	6240	6650	6°/12°
M370	3700	4000	4500	5000	2600	150	5995	6255	6665	6°/12°
M400	4000	4000	4500	5000	2800	150	6070	6330	6740	6°/12°
M425	4250	4000	4500	5000	2925	150	6095	6355	6765	6°/6°
M450	4500	3800 *4000	4300 *4500	4700 *5000	3050	150	6115	6375	6785	6°/6°
M475	4750	3700 *4000	4200 *4500	4500 *5000	3175	150	6140	6375	6810	6°/6°
M500	5000	3500 *3700	4000 *4200	4250 *4600	3300	150	6165	6425	6835	6°/6°
M550	5500	3200 *3400	3600 *4000	4000 *4200	3600	150	6255	6515	6925	6°/6°
M600	6000	*3200	*3600	*3800	3850	150	6305	6565	6975	6°/6°

### WIDE VIEW FULL 2-STAGE MAST

Mast Model	Max. Lifting Height (mm)	Load Capacity (Load Center 500mm) (Kg)			Height (mast lowered) (mm)	Free lift (with backrest) (mm)	Service Weight (Kg)			Mast Tilt angle $\alpha/\beta$ (°)
		4t	4.5t	5t			4t	4.5	5t	
ZM250	2500	4000	4500	5000	2000	785	5835	6095	6505	6°/12°
ZM300	3000	4000	4500	5000	2250	1035	5895	6155	6565	6°/12°
ZM330	3300	4000	4500	5000	2400	1185	3935	6195	6605	6°/12°
ZM350	3500	4000	4500	5000	2500	1285	5955	6215	6625	6°/12°
ZM370	3700	4000	4500	5000	2600	1385	5980	6240	6650	6°/12°
ZM400	4000	4000	4500	5000	2800	1585	6070	6330	6740	6°/12°
ZM425	4250	4000	4500	5000	2925	1710	6110	6370	6780	6°/6°
ZM450	4500	3800 *4000	4300 *4500	4700 *5000	3050	1835	6150	6410	6820	6°/6°
ZM475	4750	3700 *4000	4200 *4500	4500 *5000	3175	1960	6190	6450	6860	6°/6°
ZM500	5000	3500 *3700	4000 *4200	4250 *4600	3300	2085	6230	6490	6900	6°/6°
ZM550	5500	3200 *3400	3600 *4000	4000 *4200	3600	2385	6340	6600	7010	6°/6°
ZM600	6000	*3200	*3600	*3800	3850	2635	6395	6655	7065	6°/6°

Note: 4-5t: The free lifting height is increased by 340 mm when there is no backrest.

### WIDE VIEW FULL 3-STAGE MAST

Mast Model	Max. Lifting Height (mm)	Load Capacity (Load Center 500mm) (Kg)			Height (mast lowered) (mm)	Free lift (with backrest) (mm)	Service Weight (Kg)			Mast Tilt angle $\alpha/\beta$ (°)
		4t	4.5t	5t			4t	4.5	5t	
ZSM360	3600	3800 *4000	4350 *4500	4800 *5000	1940	730	6045	6305	6715	6°/6°
ZSM400	4000	3800 *4000	4350 *4500	4800 *5000	2080	870	6095	6355	6765	6°/6°
ZSM435	4350	3800 *4000	4350 *4500	4800 *5000	2190	980	6135	6395	6805	6°/6°
ZSM450	4500	3800 *4000	4350 *4500	4800 *5000	2240	1030	6155	6415	6825	6°/6°
ZSM470	4700	3500 *3800	4000 *4200	4500 *4800	2305	1095	6175	6435	6845	6°/6°
ZSM500	5000	3350 3500	3800 *4000	4200 *4500	2440	1230	6225	6485	6895	6°/6°
ZSM540	5400	3250 *3400	3400 *3700	3800 *4200	2590	1380	6335	6595	7005	6°/6°
ZSM600	6000	*3200	*3400	*3800	2790	1580	6410	6670	7080	6°/6°
ZSM650	6500	*2500	*2800	*3200	2990	1780	6480	6740	7150	6°/6°
ZSM700	7000	*1800	*2000	*2500	3165	1955	6545	6805	7215	6°/6°

Note: 4-5t: The free lifting height is increased by 340 mm when there is no backrest.

Load curve

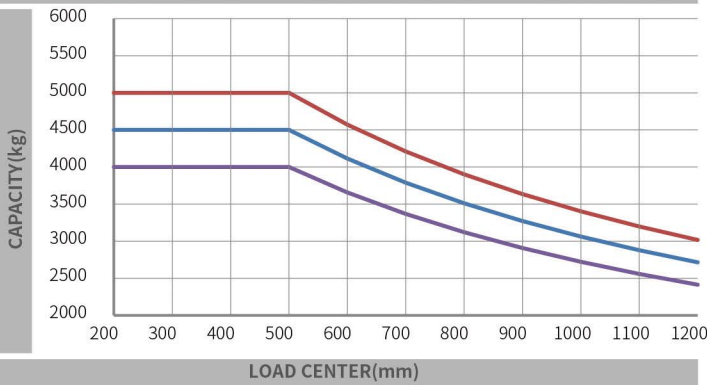

— RE40 — RE45 — RE50

**Note:** The vertical axis stands for load capacity and the horizontal axis stands for load center which is calculated from the front surface of the forks to the gravity of the standard load. the standard load means a cubic with 1000mm edge length. When mast is tilted forward, using non-standard forks or loading large goods, the load capacity will be reduced. The load capacity of standard mast at different load center can be known from this load chart.

**Configurations**

		Configurations			
Safety	Steering deceleration	●	Comfort	Semi-enclosure seat	●
	Rear handle with horn for truck reversing	●		Full suspension seat	○
	Overspeed alarm (5km/h)	○		1 USB interface (5V/1A)	●
	Overspeed alarm(8km/h)	○		Super low torque steering unit	●
	Overspeed alarm (10km/h)	○		Mechanical control valve	○
	Speed limit (no ultimate limit type)	○		Fan	○
	OPS (Travelling + Lifting + Tilting + Attachment) (Lowering is not include)	●	Cab / windshield	Panel mounted cab (with fan and wiper)	○
	Full set of OPS	○		Heater	○
	Safety switch for seat belt	●		Air conditioner only for cooling	○
	Hydraulic valve overload protection device	●		Air conditioner only for cooling + heater	○
	Dry powder extinguisher (0.5kg)	○		Front windshield (with wiper/no blow can)	○
	Dry powder extinguisher (2kg)	○		Rear windshield	○
	Backward buzzer	●	Top windshield (without fan)	○	
	Reversing speaker (Chinese)	○	Light	LED rear working lamp (one)	○
	Electronic upper buffering	○		Rear LED red/blue spot lamp	○
	Wide- angle central rearview mirror	●		Left, right and rear blue bar	○
	Rearview mirror on two sides + Center wide angle rearview mirror	○		Fixed type LED flicker warning lamp	●
	Reverse radar (4 probes)	○		Fixed type LED rotating warning lamp	○
	Reversing image (1 camera + 4 probes)	○		Fixed type LED rotating buzzer warning lamp	○
			Other	Sleeve for steering cylinder	●
		Sleeves for steering cylinder and tilting cylinder		○	
		FICS standard type (domestic)		○	

**ト BOMAC**

エクストラ ワークス エクストラ ストロング